

PARKING LOT LIGHT SERIES

HIGH POWERED PARKING LOT LIGHT

Spitzer
LIGHTING

INSTALLATION MANUAL

PRODUCT PARAMETER	
INPUT VOLTAGE	120-277 / 277-480V
DRIVER	SOSEN POWER
MATERIAL	ALUMINUM & PC

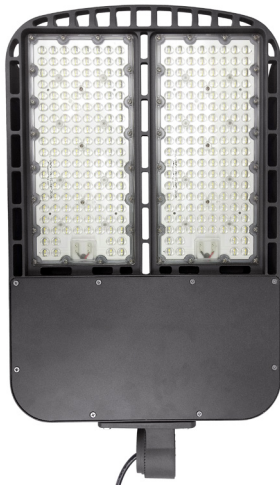

PRE - INSTALLATION

- Carefully remove the fixture from the carton.
- Before beginning assembly, installation, or operation of product, make sure all parts are present. Compare parts with package contents list and diagram on previous page. If any part is missing or damaged, do not attempt to assemble, install or operate the product. Contact customer service for replacement parts.
- Tools required for assembly (Not Included): screwdriver, phillips screwdriver, pliers, electrical tape, wire cutters, safety glasses, ladder, wire stripper.

SAFETY INFORMATION

BE SURE THE POWER IS OFF! RISK OF ELECTRICAL SHOCK: Always use the switch to power off. Do not perform any operations while this unit is powered on. The electrical system you want to connect the device to must be grounded. Read the instructions before using or powering this device. The safety instructions must remain with the unit in case of transfer. Any damage to the device linked to an inappropriate use is excluded from support by the warranty. Before connecting, make sure that the current and voltage are compatible with this device. We highly recommend that all installations are made by QUALIFIED ELECTRICIAN. We are NOT responsible by any means for the use or misuse of the following information. We are NOT responsible in whole or part for any harm or damage that may or may not be caused. We reserve the right to revise the components of any product, due to part availability or change ETL, CUL, UL standards without assuming any obligation or liability to modify any products previously manufactured and without notice. These instructions do not cover all details of variations in equipment, nor do they provide every possible contingency to be met. Turn off / unplug power when installing or service device.

WARNING

WARNING: Read all safety precautions and installation instructions carefully before installing or servicing this fixture. Failure to comply with these instructions could result in a potentially fatal electric shock, fire, and/or property damage.

- This product must be installed according to the instructions. And installed by a person familiar with the product, production and product hazards
- Avoid fire and electric shock . When installing the lighting fixtures, you need to understand the electrical characteristics. If you are not sure, do not attempt to install. Please contact an electrician
- Make sure you understand the structural features and dimensions of lighting before installation
- Do not drill holes or change internal lines when the product is installed

FCC WARNING

WARNING: Changes or modifications to this unit not expressly approved by the party responsible for compliance could void the user authority to operate the equipment.

NOTES: This equipment has been tested and found to comply with the limits for a Class B digital device, pursuant to Part 15 of the FCC Rules. These limits are designed to provide reasonable protection against harmful interference in a residential installation. This equipment generates, uses and can radiate radio frequency energy and, if not installed and used in accordance with the instructions, may cause harmful interference to radio communications.

However, there is no guarantee that interference will not occur in a particular installation. If this equipment does cause harmful interference to radio or television reception, which can be determined by turning the equipment off and on, the user is encouraged to try to correct the interference by one or more of the following measures:

- Reorient or relocate the receiving antenna.
- Increase the separation between the equipment and receiver.
- Connect the equipment into an outlet on a circuit different from that to which the receiver is connected.
- Consult the dealer or an experienced radio/TV technician for help.

SLIP-FITTER INSTALLATION (Caution: Before beginning installation turn off the circuit breaker and light switch)

Square Pole Installation

STEP 1

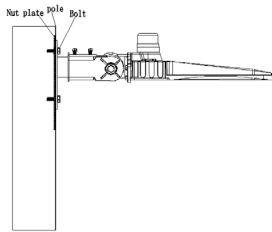

Drill holes on the square pole corresponding to the holes on the square bar adapter, and use the bolt and nut plate to fix the fixture to the adapter tightly.

STEP 2

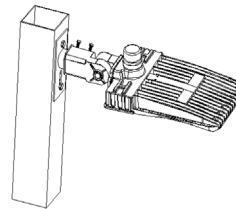

Connect the AC wire of the fixture and tighten the water-proof gasket and cover plate on the square bar adapter by screws, then power on.

Round Pole Installation

STEP 1

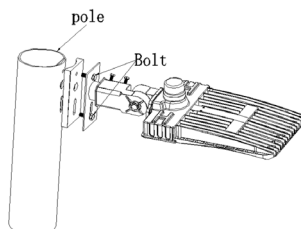

Drill holes on the round pole corresponding to the holes on the round bar adapter, and use the bolt and nut plate to fix the fixture to the adapter tightly.

STEP 2

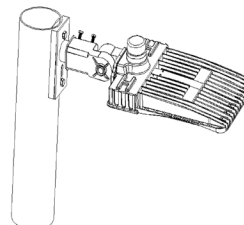

Connect the AC wire of the fixture and tighten the water-proof gasket and cover plate on the square bar adapter by screws, then power on.

PARKING LOT LIGHT SERIES

HIGH POWERED PARKING LOT LIGHT

Spitzer
LIGHTING

INSTALLATION MANUAL

TRUNNION INSTALLATION (Caution: Before beginning installation turn off the circuit breaker and light switch)

STEP 1 →

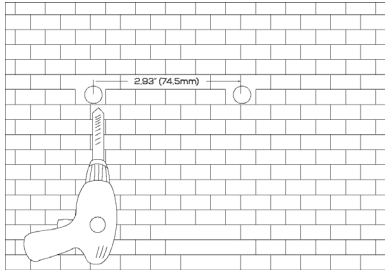

Drill two holes on the wall corresponding to the holes on the trunnion and knock expansion screws into the holes.

STEP 2 →

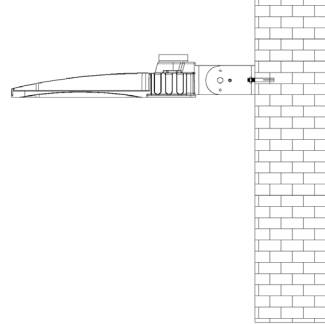

Use the nuts to fix the fixture to the wall aiming at the expansion screws, and adjust angle of the bracket and tighten the small screw on the side, then connect the AC wire.

ARM MOUNT INSTALLATION (Caution: Before beginning installation turn off the circuit breaker and light switch)

Square Pole Installation

STEP 1 →

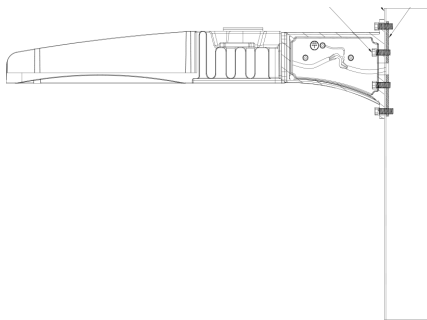

Drill holes on the square pole corresponding to the holes on the arm, and use the bolt and nut plate to fix the fixture to the pole tightly.

STEP 2 →

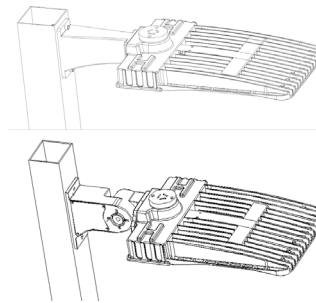

Connect the AC wire of the fixture and tighten the water-proof gasket and cover plate on the arm by screws, then power on.

Round Pole Installation

Nut Plate

Bolt

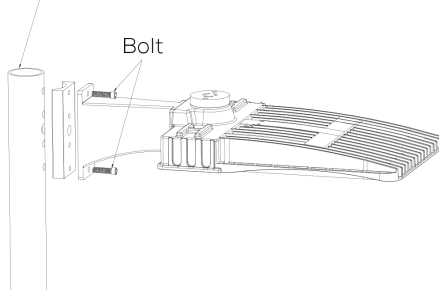

Drill holes on the round pole corresponding to the holes on the arm, and use the bolt and nut plate to fixture to the pole tightly.

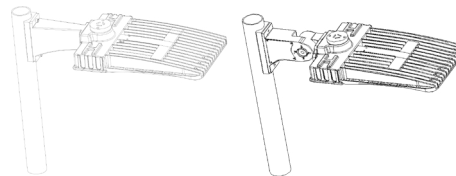

Connect the AC wire of the fixture and tighten the water-proof gasket and cover plate on the arm by screws, then power on.

TROUBLE SHOOTING

PROBLEM	POSSIBLE CAUSE	SOLUTION
Light will not come on	A. Light switch is turned off B. Fuse is blown or circuit breaker is turned off C. Incorrect circuit wiring	A. Turn light switch on B. Replace fuse or turn circuit breaker on C. Verify that fixture is wired properly

CARE AND MAINTENANCE

CAUTION: Before attempting to clean the fixture, disconnect the power to the fixture by turning the breaker off or removing the fuse from the fuse box. This LED light fixture is made from quality materials that will last many years with minimum care and maintenance. You may want to clean the fixture with a soft cloth periodically. To maintain the best appearance of the fixture, do not use cleaners with chemicals, solvents or harsh abrasives. Do not use liquid cleaner on the LEDs, LED driver, or wiring inside the light fixture.

PARKING LOT LIGHT SERIES

HIGH POWERED PARKING LOT LIGHT

Spitzer
LIGHTING

INSTALLATION MANUAL

PRODUCT SETTINGS

By selecting the combination on the dip switches, sensor data can be precisely set for each specific application.

		1	2	
ON ↑ [DIP SWITCH]	I	ON	ON	100%
	II	ON	-	75%
	III	-	ON	50%
	IV	-	-	10%

DETECTION AREA

Detection area can be reduced by selecting the combination on the DIP switches to fit precisely each application.

		6	7	8	
ON ↑ [DIP SWITCH]	I	ON	ON	ON	0s
	II	-	ON	ON	5s
	III	ON	-	ON	5min
	IV	-	-	ON	10min
	V	ON	ON	-	30min
	VI	-	ON	-	1h
	VII	-	-	-	Disable

HOLD TIME

Refers to the time period the lamp remains at 100% illumination after no motion detected.

		3	4	5	
ON ↑ [DIP SWITCH]	I	ON	ON	ON	5s
	II	-	ON	ON	30s
	III	ON	-	ON	90s
	IV	-	-	ON	3min
	V	ON	ON	-	20min
	VI	-	-	-	+∞

STAND-BY PERIOD

Refers to the time period the lamp remains at a low light level before it completely switches off in the long absence of people. When set to "+∞" mode, the low light is maintained until motion is detected.

		1	2	3	4	
ON ↑ [DIP SWITCH]	I	-	-	ON	ON	2Lux
	II	-	-	-	ON	5Lux
	III	-	ON	ON	-	10Lux
	IV	-	-	ON	-	25Lux
	V	-	ON	-	-	50Lux
	VI	ON	-	-	-	100Lux
	VII	-	-	-	-	Disable

DAYLIGHT SENSOR

The sensor can be set to only allow the lamp to illuminate below a defined ambient brightness threshold. When set to "Disable" mode, the daylight sensor will switch on the lamp when motion is detected regardless of ambient light level. 50lux, 30lux: twilight operation, 10lux, 5lux: darkness operation only. Note that daylight sensor is active only when the lamp totally switches off.

		5	6	
ON ↑ [DIP SWITCH]	I	ON	ON	50%
	II	-	ON	30%
	III	ON	-	20%
	IV	-	-	10%

STAND-BY DIMMING LEVEL

The low light level you would like to have after the hold time in the long absence of people.

PARKING LOT LIGHT SERIES

HIGH POWERED PARKING LOT LIGHT

Spitzer
LIGHTING

INSTALLATION MANUAL

PHOTOCELL INSTALLATION

Slip-Fitter Installation

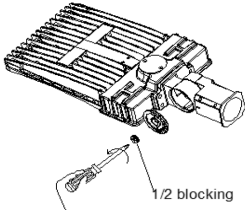

Remove the round cap on the luminaire and unscrew the 1/2 screw.

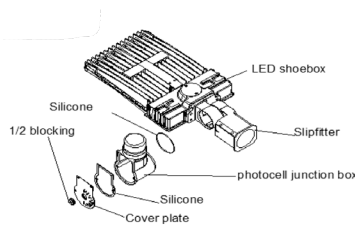

Remove the components of the photocell junction box and fix the photocell junction box on the High Powered Parking Lot Light (Slip-Fitter installation mode).

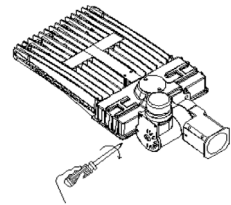

The photocell junction box is assembled according to previous disassembled chart and connected with AC power supply cable (as shown).

Arm Mount Installation

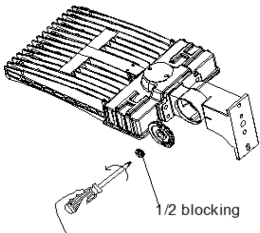

Remove the round cap on the luminaire and unscrew the 1/2 screw.

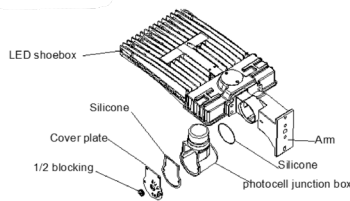

Remove the components of the photocell junction box and fix the photocell junction box on the High Powered Parking Lot Light (arm mount installation mode).

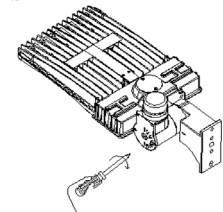

The photocell junction box is assembled according to previous disassembled chart and connected with AC power supply cable (as shown).

Wiring Drawing for Photocell

